

SARAY[®] | OVAL SÜRME



YALITIMSIZ SÜRME SERİ

SARAY[®] | Alüminyum

Mükemmel yapılar için...

- Profiller
- Profiles

Oval Yalıtımsız Sürme Serisi

Yalıtımsız 38' lik Sürme Seri

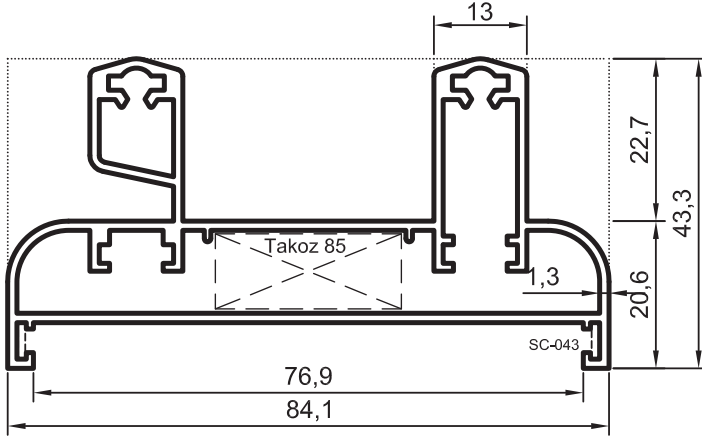

No : 1872

Sürme Kasa
1,300 kg/m

$$J_x = 7,33 \text{ cm}^4$$

$$J_y = 33,24 \text{ cm}^4$$

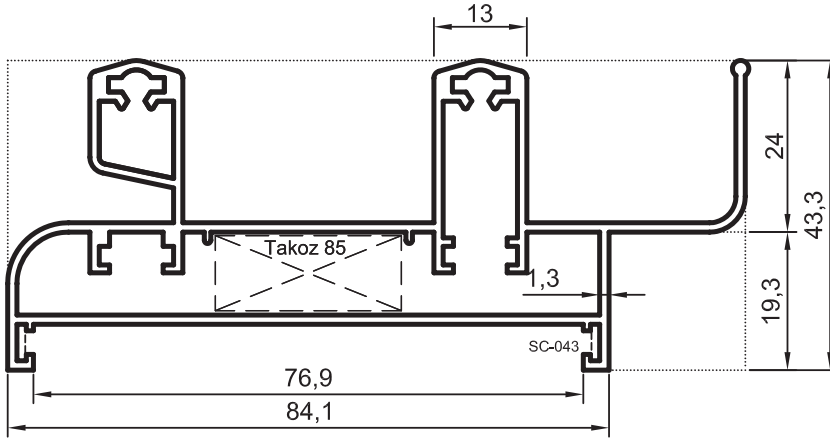

No : 12959

Sürme Kasa
1,455 kg/m

$$J_x = 7,78 \text{ cm}^4$$

$$J_y = 49,73 \text{ cm}^4$$

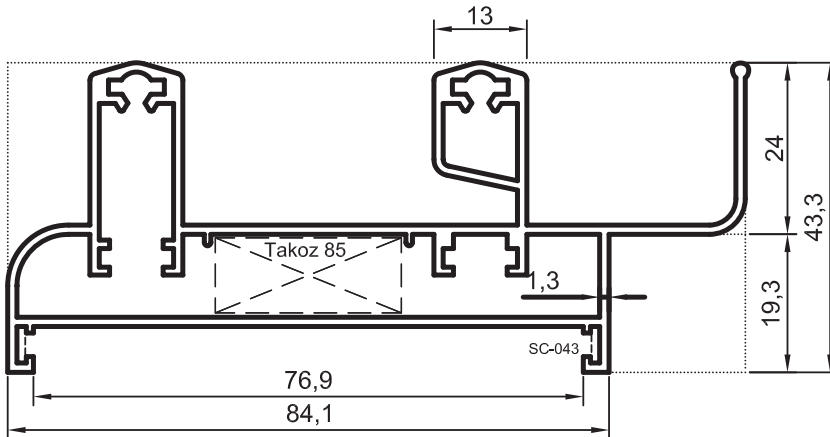

No : 13480

Sürme Kasa
1,455 kg/m

$$J_x = 7,76 \text{ cm}^4$$

$$J_y = 49,16 \text{ cm}^4$$

Uyarı: Profil ağırlıklarımız teorik olup; teslim anındaki tartımız geçerlidir. Warning: the weights of profile is theoretical, weighting at the time of delivery are valid.

- Profiller
- Profiles

Oval Yalıtımsız Sürme Serisi

Yalıtımsız 38' lik Sürme Serisi

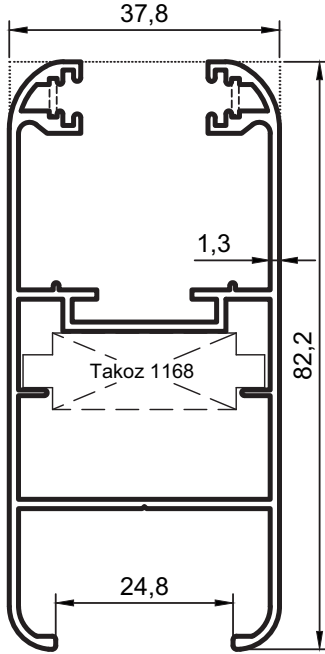

No : 1870

Sürme Kanat $J_x = 22,87 \text{ cm}^4$
1,090 kg/m $J_y = 9,41 \text{ cm}^4$

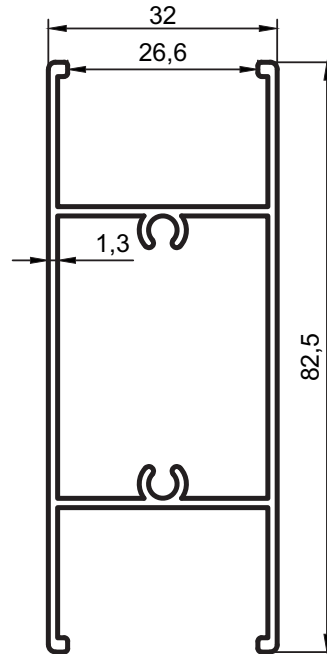

No : 909

Sürme Kayıt $J_x = 17,73 \text{ cm}^4$
0,890 kg/m $J_y = 5,81 \text{ cm}^4$

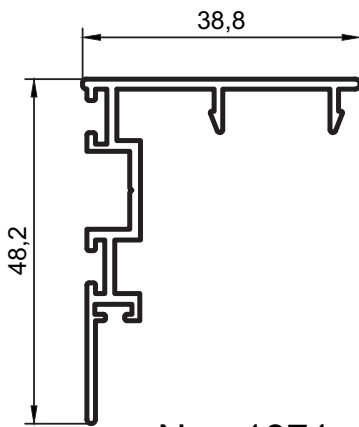

No : 1871

Sürme Kenet
0,465 kg/m

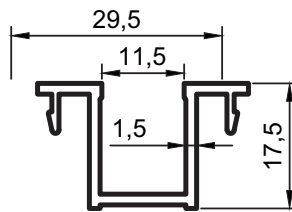

No : 866-1870 (veya -866-869)

Tek Cam Adaptörü
0,290 kg/m

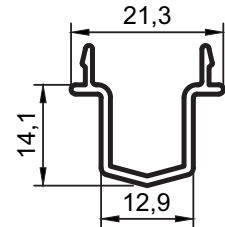

No : 1843

Orta Kenet
0,190 kg/m

Uyarı: Profil ağırlıklarımız teorik olup; teslim anındaki tartımız geçerlidir. Warning: the weights of profile is theoretical, weighting at the time of delivery are valid.

- Profiller
- Profiles

Oval Yalıtımsız Sürme Serisi

Yalıtımsız 32' lik Sürme Serisi

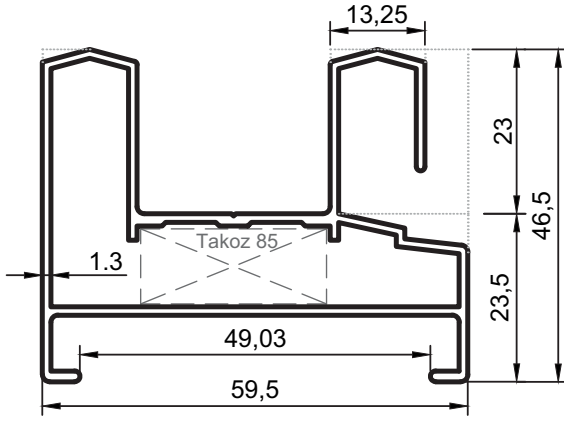

No : 868

Sürme Kasa
0,880 kg/m

$$J_x = 5,66 \text{ cm}^4$$

$$J_y = 13,82 \text{ cm}^4$$

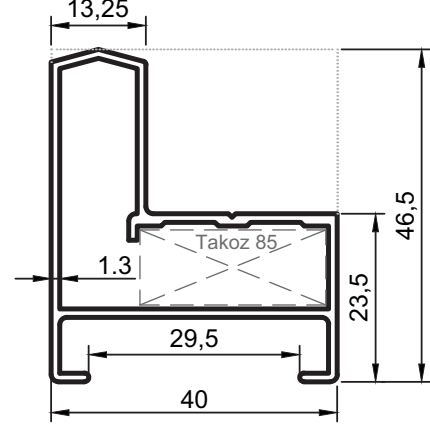

No : 888

Sürme Kasa
0,600 kg/m

$$J_x = 2,59 \text{ cm}^4$$

$$J_y = 5,43 \text{ cm}^4$$

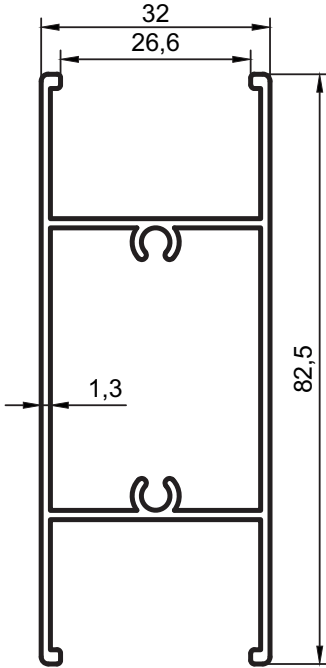

No : 909

Sürme Kayıt
0,890 kg/m

$$J_x = 17,73 \text{ cm}^4$$

$$J_y = 5,81 \text{ cm}^4$$

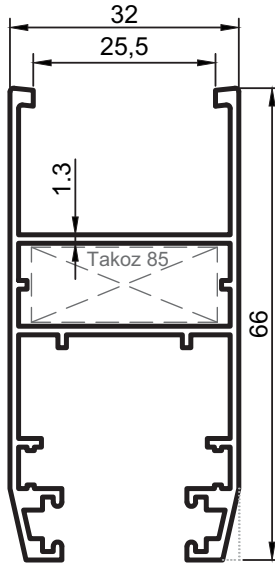

No : 869

Sürme Kanat
0,815 kg/m

$$J_x = 10,73 \text{ cm}^4$$

$$J_y = 5,25 \text{ cm}^4$$

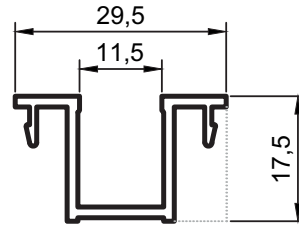

No : 866-869

Tek Cam Adaptörü
0,290 kg/m

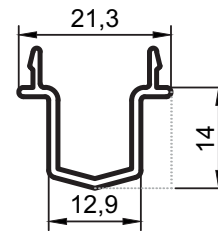

No : 1843

Orta Kenet
0,190 kg/m

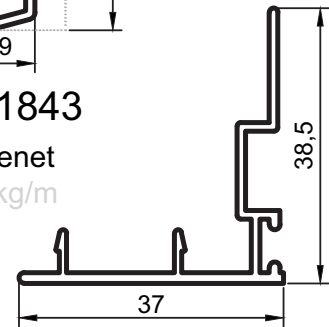

No : 867

Sürme Kenet
0,350 kg/m

Uyarı: Profil ağırlıklarımız teorik olup; teslim anındaki tartımız geçerlidir. Warning: the weights of profile is theoretical, weighting at the time of delivery are valid.

- Profiller
- Profiles

Oval Yalıtımsız Sürme Serisi

Yalıtımsız 32' lik Sürme Seri

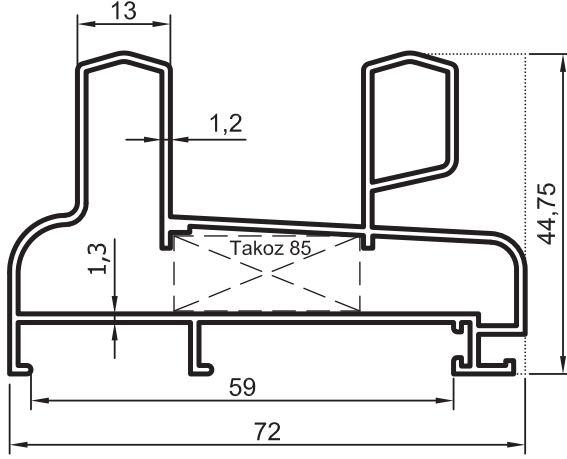

No : 1877

Sürme Kasa $J_x = 6,28 \text{ cm}^4$
1,010 kg/m $J_y = 18,72 \text{ cm}^4$

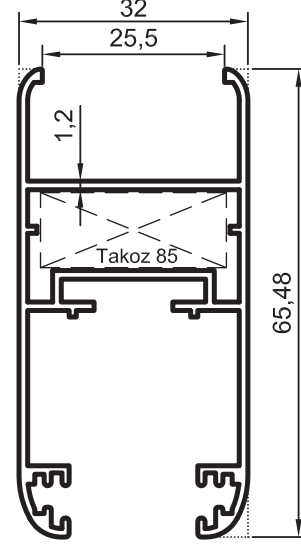

No : 1878

Sürme Kanat $J_x = 9,99 \text{ cm}^4$
0,810 kg/m $J_y = 5,03 \text{ cm}^4$

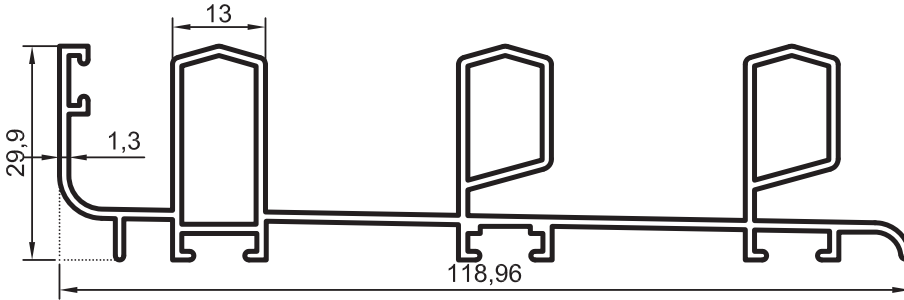

No : 7464

Üçlü Sürme Kasa $J_x = 3,97 \text{ cm}^4$
1,300 kg/m $J_y = 62,02 \text{ cm}^4$

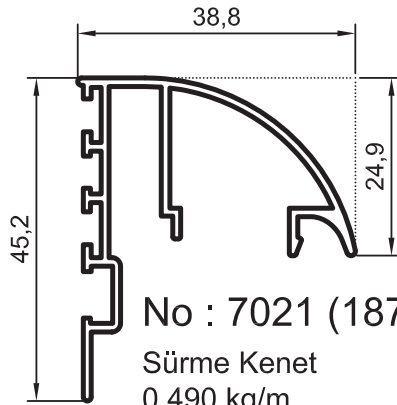

No : 7021 (1879 Yerine)

Sürme Kenet
0,490 kg/m

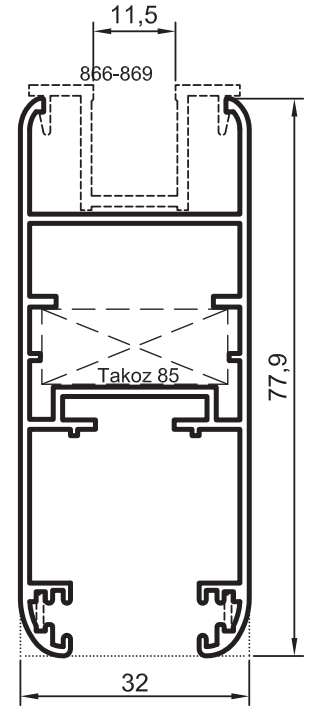

No : 7352

Sürme Kanat
0,980 kg/m

Uyarı: Profil ağırlıklarımız teorik olup; teslim anındaki tartımız geçerlidir. Warning: the weights of profile is theoretical, weighting at the time of delivery are valid.

- Profiller
- Profiles

Oval Yalıtımsız Sürme Serisi

Yalıtımsız 28' lik Sürme Seri

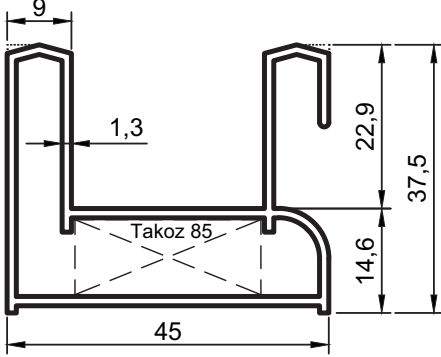

No : 898

Sürme Kasa $J_x = 3,66 \text{ cm}^4$
0,700 kg/m $J_y = 6,79 \text{ cm}^4$

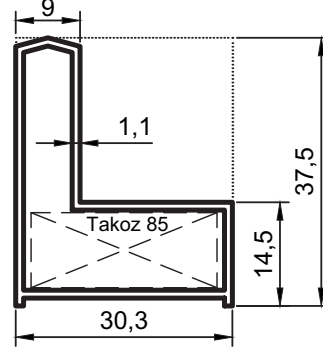

No : 855

Sürme Kasa $J_x = 0,95 \text{ cm}^4$
0,390 kg/m $J_y = 2,45 \text{ cm}^4$

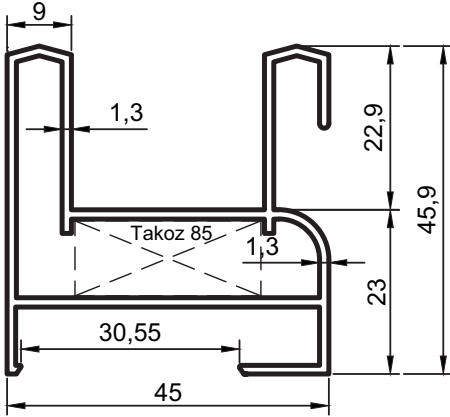

No : 1873

Sürme Kasa $J_x = 5,04 \text{ cm}^4$
0,800 kg/m $J_y = 8,32 \text{ cm}^4$

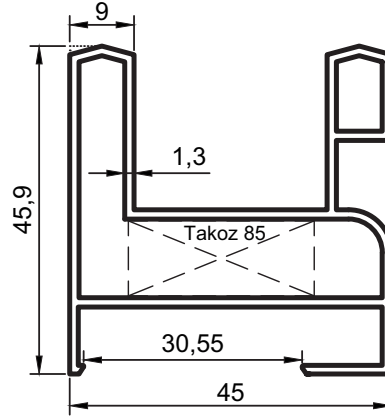

No : 1893

Sürme Kasa $J_x = 5,25 \text{ cm}^4$
0,815 kg/m $J_y = 8,54 \text{ cm}^4$

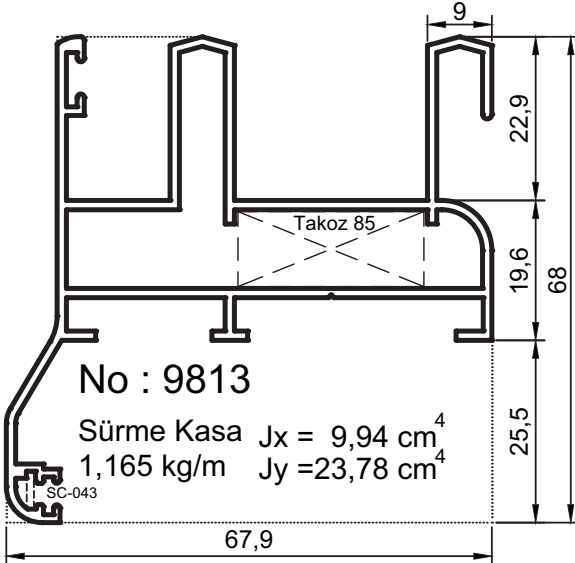

No : 9813

Sürme Kasa $J_x = 9,94 \text{ cm}^4$
1,165 kg/m $J_y = 23,78 \text{ cm}^4$

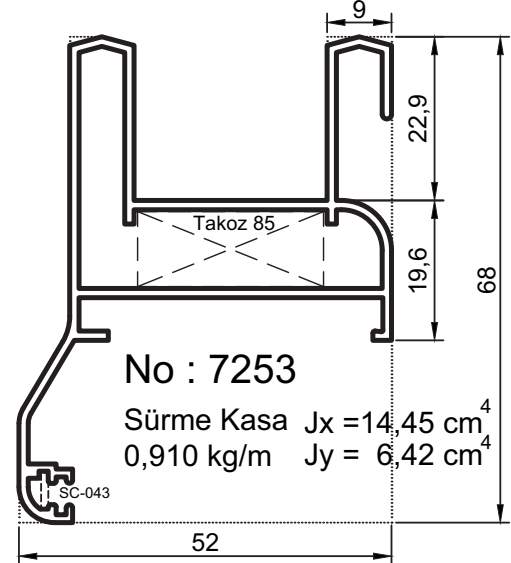

No : 7253

Sürme Kasa $J_x = 14,45 \text{ cm}^4$
0,910 kg/m $J_y = 6,42 \text{ cm}^4$

Uyarı: Profil ağırlıklarımız teorik olup; teslim anındaki tartımız geçerlidir. Warning: the weights of profile is theoretical, weighting at the time of delivery are valid.

- Profiller
- Profiles

Oval Yalıtımsız Sürme Serisi

Yalıtımsız 28' lik Sürme Seri

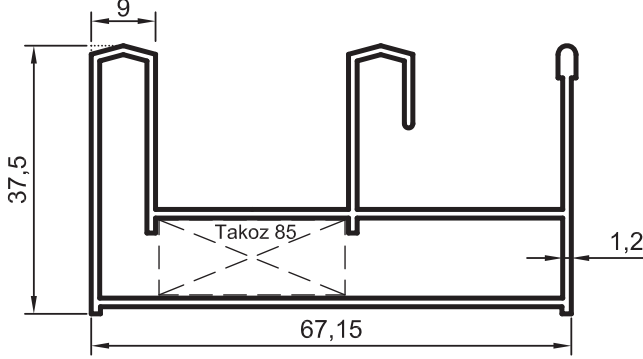

No : 5813

Sineklikli Sürme Kasa
0,915 kg/m

$$J_x = 4,57 \text{ cm}^4$$

$$J_y = 17,71 \text{ cm}^4$$

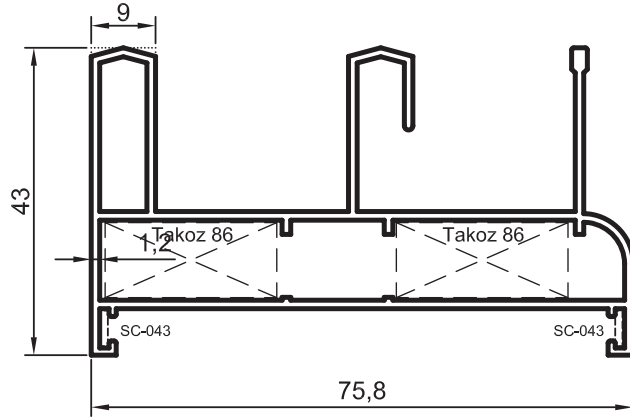

No : 12 564

Sineklikli Sürme Kasa
1,020 kg/m

$$J_x = 5,38 \text{ cm}^4$$

$$J_y = 24,92 \text{ cm}^4$$

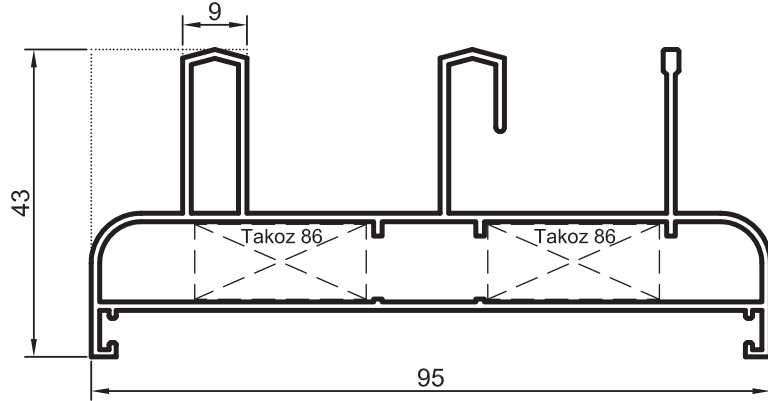

No : 13 166

Sineklikli Sürme Kasa
1,140 kg/m

$$J_x = 5,80 \text{ cm}^4$$

$$J_y = 36,20 \text{ cm}^4$$

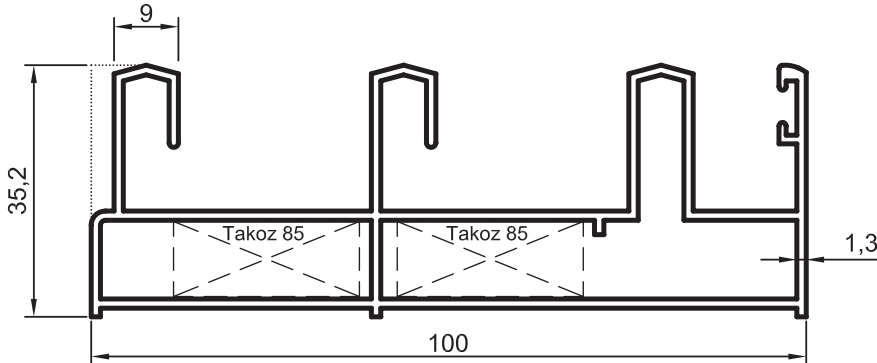

No : 6569

Sürme Kasa
1,340 kg/m

$$J_x = 5,90 \text{ cm}^4$$

$$J_y = 51,88 \text{ cm}^4$$

Uyarı: Profil ağırlıklarımız teorik olup; teslim anındaki tartımız geçerlidir. Warning: the weights of profile is theoretical, weighting at the time of delivery are valid.

- Profiller
- Profiles

Oval Yalıtımsız Sürme Serisi

Yalıtımsız 28' lik Sürme Seri

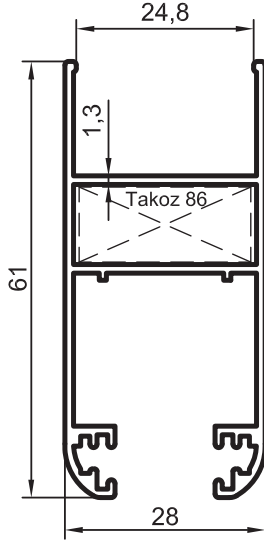

No : 900

Sürme Kanat $J_x = 7,64 \text{ cm}^4$
 0,690 kg/m $J_y = 3,34 \text{ cm}^4$

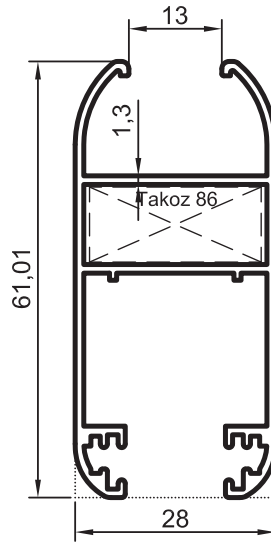

No : 900-B

Sürme Kanat $J_x = 8,28 \text{ cm}^4$
 0,710 kg/m $J_y = 3,28 \text{ cm}^4$

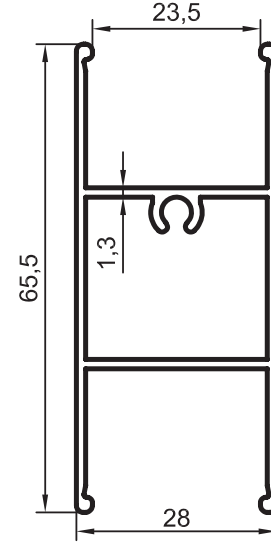

No : 896

Sürme Kayıt $J_x = 7,68 \text{ cm}^4$
 0,700 kg/m $J_y = 3,47 \text{ cm}^4$

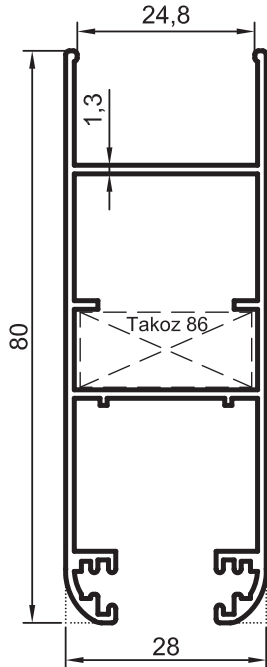

No : 13469

Sürme Kanat $J_x = 16,86 \text{ cm}^4$
 0,830 kg/m $J_y = 4,28 \text{ cm}^4$

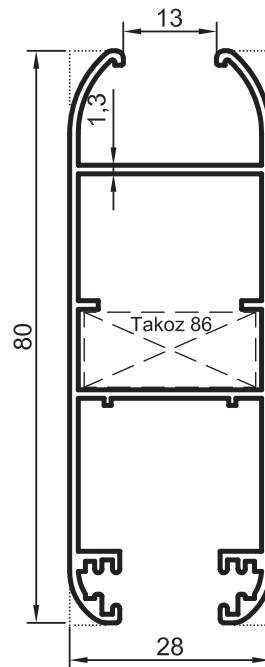

No : 13470

Sürme Kanat $J_x = 18,00 \text{ cm}^4$
 0,845 kg/m $J_y = 4,20 \text{ cm}^4$

Uyarı: Profil ağırlıklarımız teorik olup; teslim anındaki tartımız geçerlidir. Warning: the weights of profile is theoretical, weighting at the time of delivery are valid.

- Profiller
- Profiles

Oval Yalıtımsız Sürme Serisi

Yalıtımsız 28' lik Sürme Seri

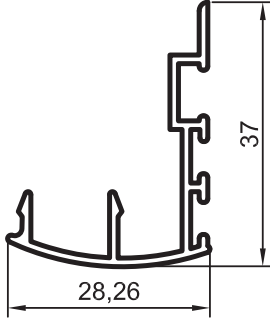

No : 901

Sürme Kenet
0,320 kg/m

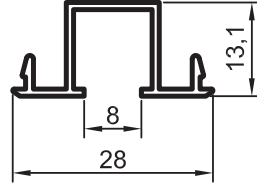

No : 866-900

Tek Cam Adaptörü
0,180 kg/m

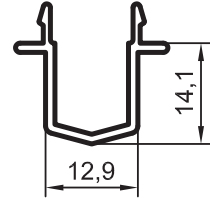

No : 1827

Orta Adaptör
0,190 kg/m

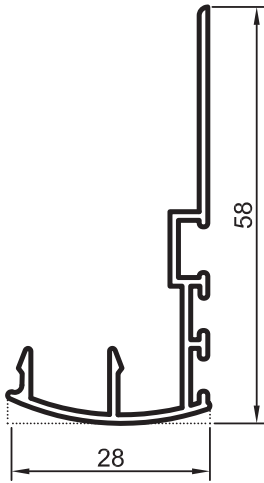

No : 13475

Sürme Kenet
0,390 kg/m

13475 Profili Montaj Detayı

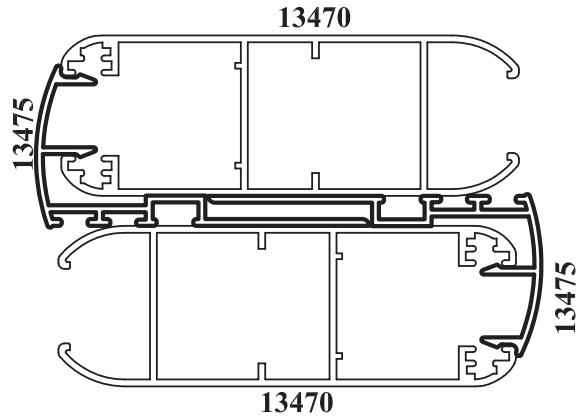
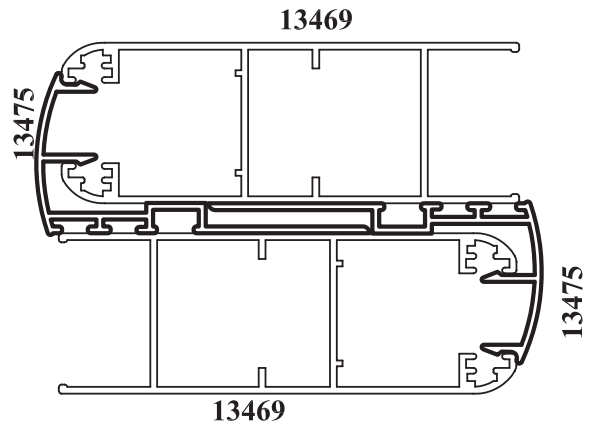

- Profiller
- Profiles

Oval Yalıtımsız Sürme Serisi

Yalıtımsız 28' lik Sürme Seri

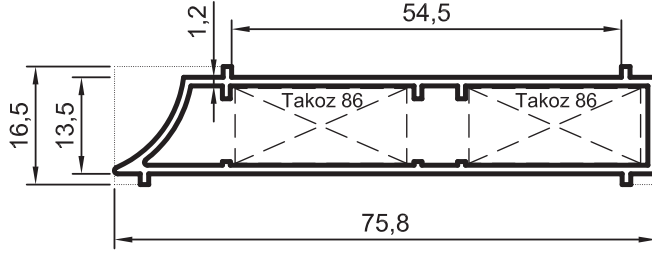

No : 13154

Sabite Geçiş Profili
0,585 kg/m

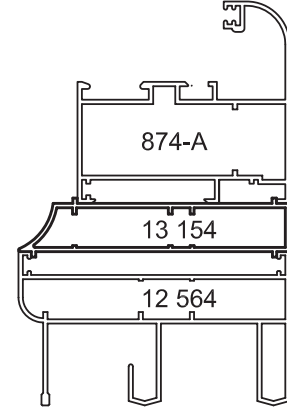

Sabite Geçiş Profili Montaj Detayı

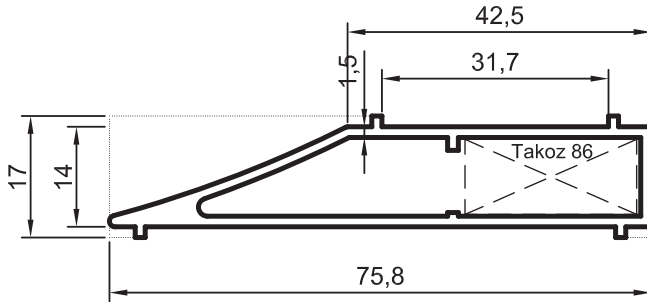

No : 13684

Sabite Geçiş Profili
0,710 kg/m

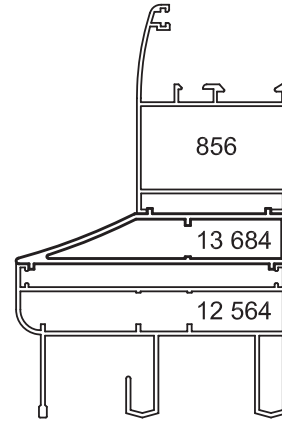

Sabite Geçiş Profili Montaj Detayı

Uyarı: Profil ağırlıklarımız teorik olup; teslim anındaki tartımız geçerlidir. Warning: the weights of profile is theoretical, weighting at the time of delivery are valid.

- Profiller
- Profiles

Oval Yalıtımsız Sürme Serisi

Sineklik Profilleri

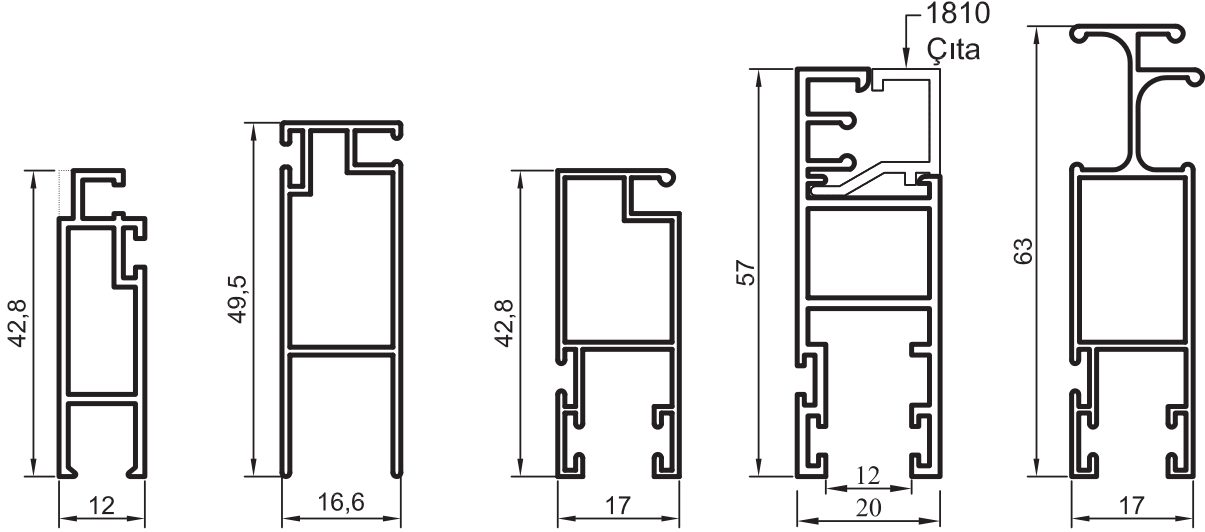

No : 2780

Sineklik Profili
0,400 kg/m

No : 12449

Sineklik Profili
0,430 kg/m

No : 11871

Sineklik Profili
0,390 kg/m

No : 1809

Sineklik Kanadı
0,730 kg/m

No : 12955

Sineklik Profili
0,560 kg/m

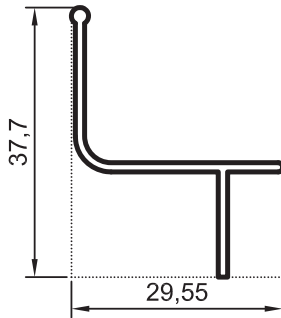

No : 7023

Sineklik Ray Profili
0,230 kg/m

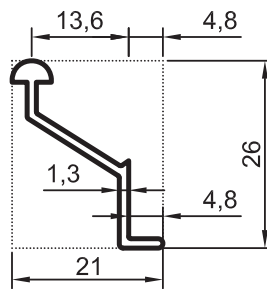

No : 1821

Sineklik Ray
0,170 kg/m

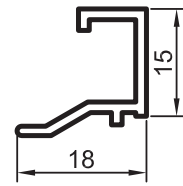

No : 1810

Sineklik Çıtası
0,180 kg/m

- Profiller
- Profiles

Oval Yalıtımsız Sürme Serisi

Pervaz Profilleri

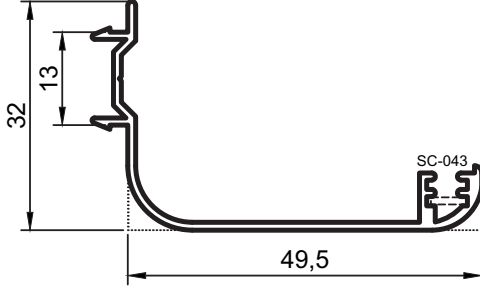

No : 1844

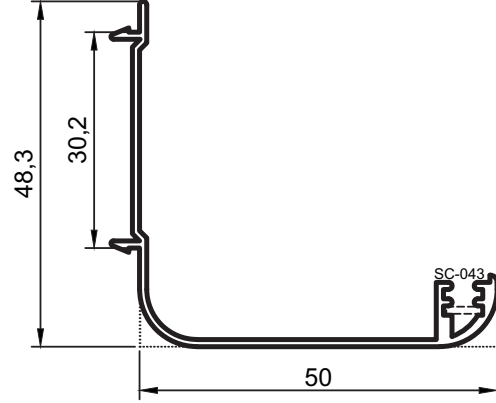
Pervaz
0,320 kg/m

No : 859

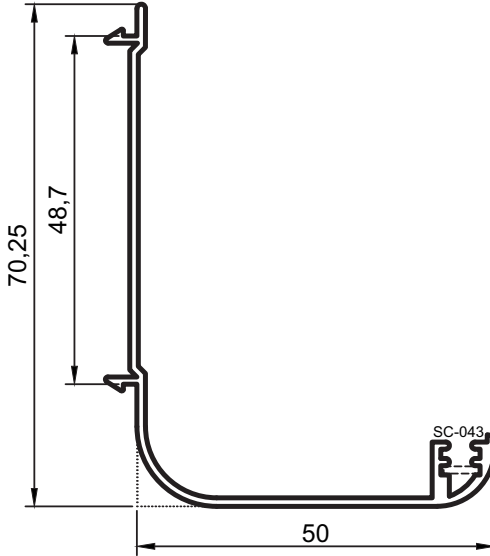
Pervaz
0,360 kg/m

No : 1874

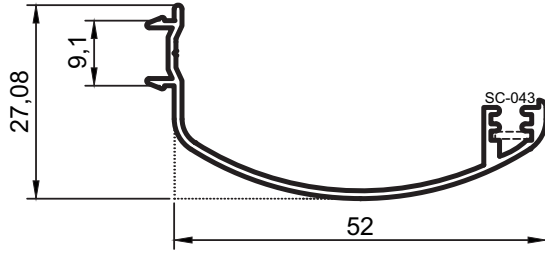
Pervaz
0,480 kg/m

No : 1892

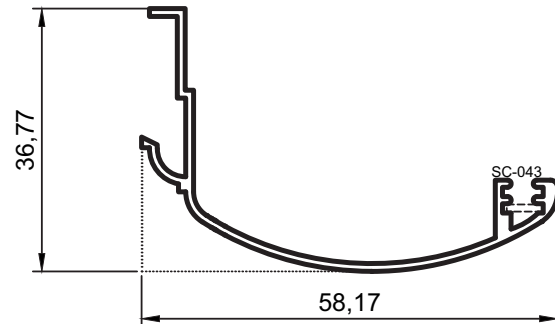
Pervaz (1891-6699-6786 ile çalışır.)
0,305 kg/m



No : 1896

Pervaz
0,360 kg/m

Uyarı: Profil ağırlıklarımız teorik olup; teslim anındaki tartımız geçerlidir. Warning: the weights of profile is theoretical, weighting at the time of delivery are valid.

**OVAL UNINSULATED
SLIDING SYSTEM
GASKETS and ACCESSORIES**

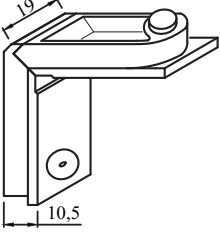
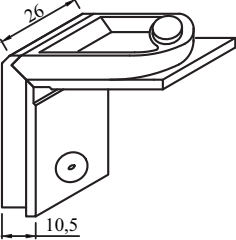
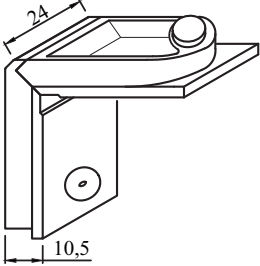
**OVAL YALITIMSIZ
SÜRME SİSTEMİ
CONTA ve AKSESUARLAR**

• Aksesuarlar • Accessories		Oval Yalıtımsız Sürme Serisi		
Çizim DRAWING	Aksesuar Kodu CODE	Malzeme MATERIAL	Malzeme Tanımı DESCRIPTION	Koli / Paket PACKAGING
	TAKOZ 84	Metal	Oval Seri Bağlantı (10.5x19) Corner Cleat	250 ad/koli
	TAKOZ 85	Metal	Oval Seri Bağlantı (10.5x26) Corner Cleat	100 ad/koli
	TAKOZ 86	Metal	Oval Seri Bağlantı (10.5x24) Corner Cleat	250 ad/koli
	TAKOZ 1168 (34-01)	Metal	Oval Seri Bağlantı (8x33.8) Corner Cleat	250 ad/koli

- Aksesuarlar
- Accessories

Oval Yalıtımlı-Yalıtımsız Seri

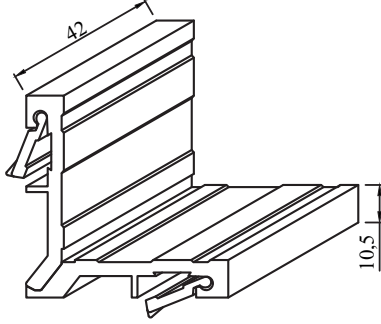

No : Takoz 81

Yalıtımsız Dar Kanat Bağlantı
(100 Adet/Pk)

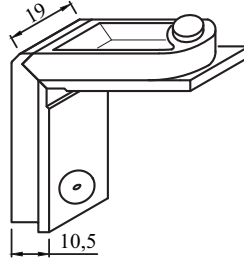

No : Takoz 84

(250 Adet/Pk)

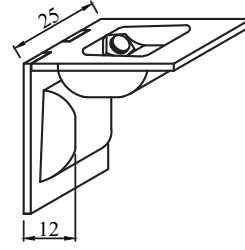

No : Takoz 87

(100 Adet/Pk)

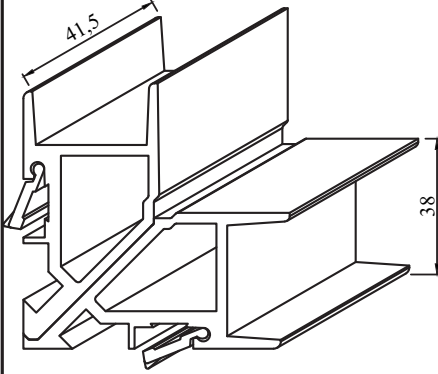

No : Takoz 82

Yalıtımsız Geniş Kanat Bağlantı
(150 Adet/Pk)

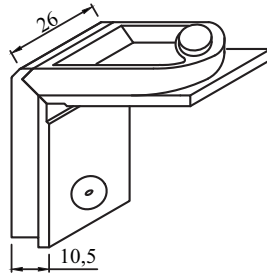

No : Takoz 85

(250 Adet/Pk)

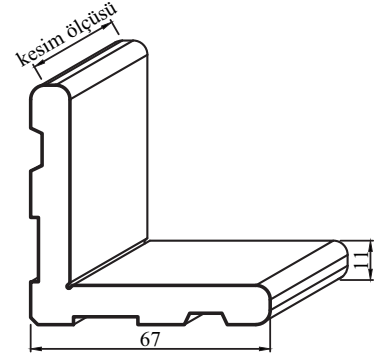

No : 858

Köşe Takozu
3,230 kg/m

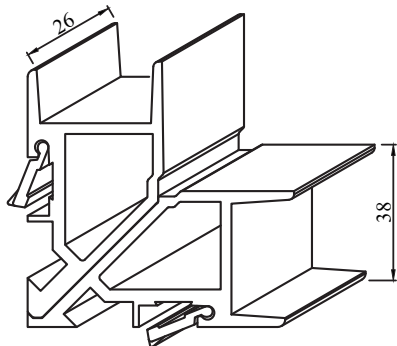

No : Takoz 83

Yalıtımlı Geniş Kanat Bağlantı
(150 Adet/Pk)

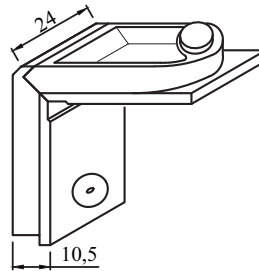

No : Takoz 86

(250 Adet/Pk)

Ölçek : 1/2

Uyarı: Profil ağırlıklarımız teorik olup; teslim anındaki tartımız geçerlidir. Warning: the weights of profile is theoretical, weighting at the time of delivery are valid.

**OVAL UNINSULATED
SLIDING SYSTEM DETAIL**
OVAL YALITIMSIZ
SÜRME SİSTEM DETAYLARI

- Detaylar
- Details

Oval Yalıtımsız Sürme Seri

Sürme 32' lik Seri

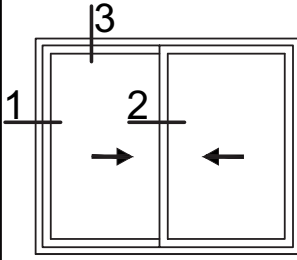

sineklik detayı

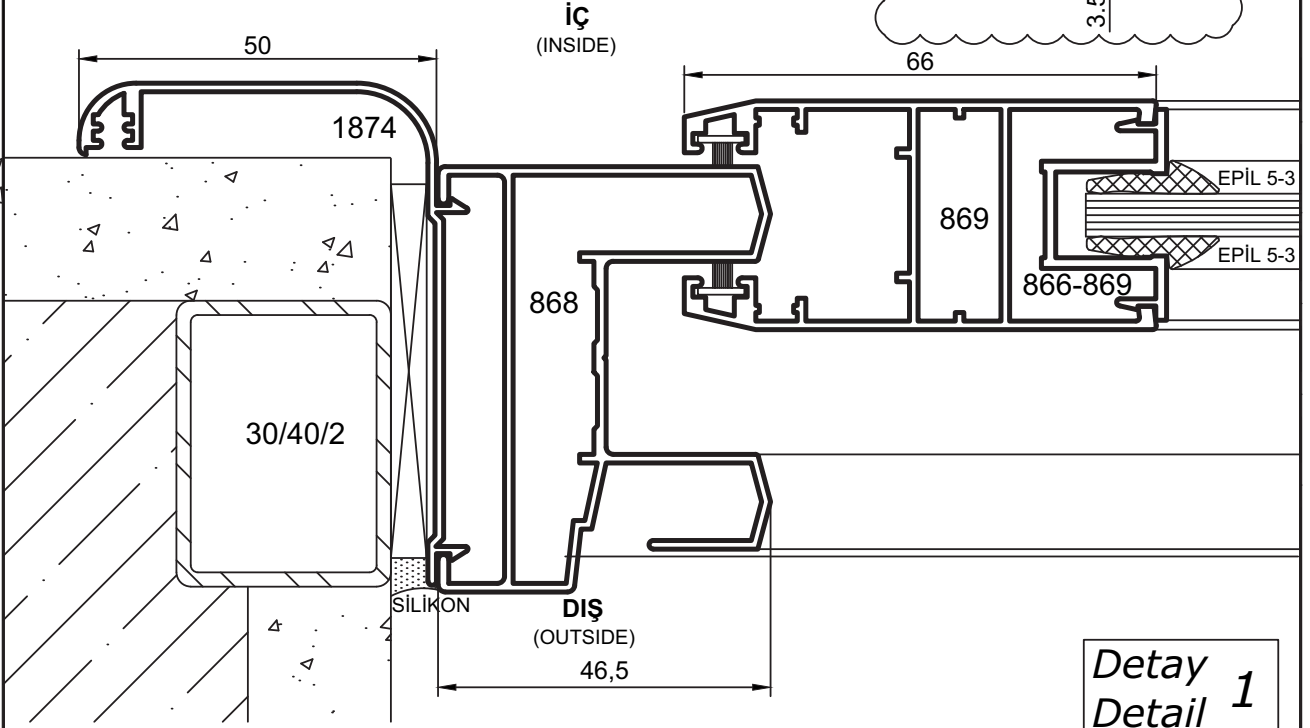
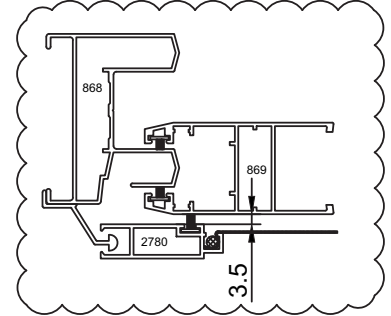

*Detay
Detail 1*

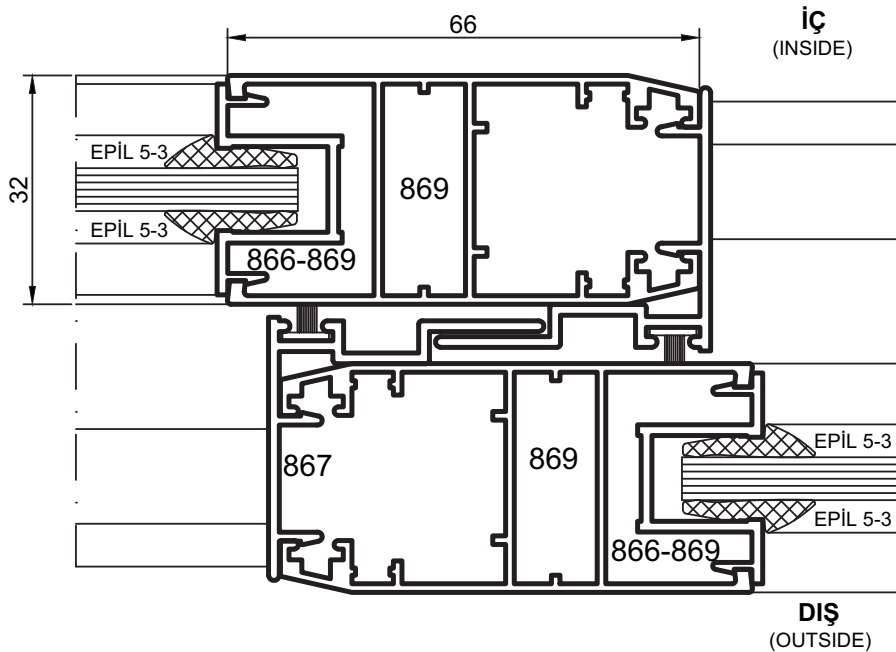

*Detay
Detail 2*

- Detaylar
- Details

Oval Yalıtımsız Sürme Seri

Sürme 32' lik Seri

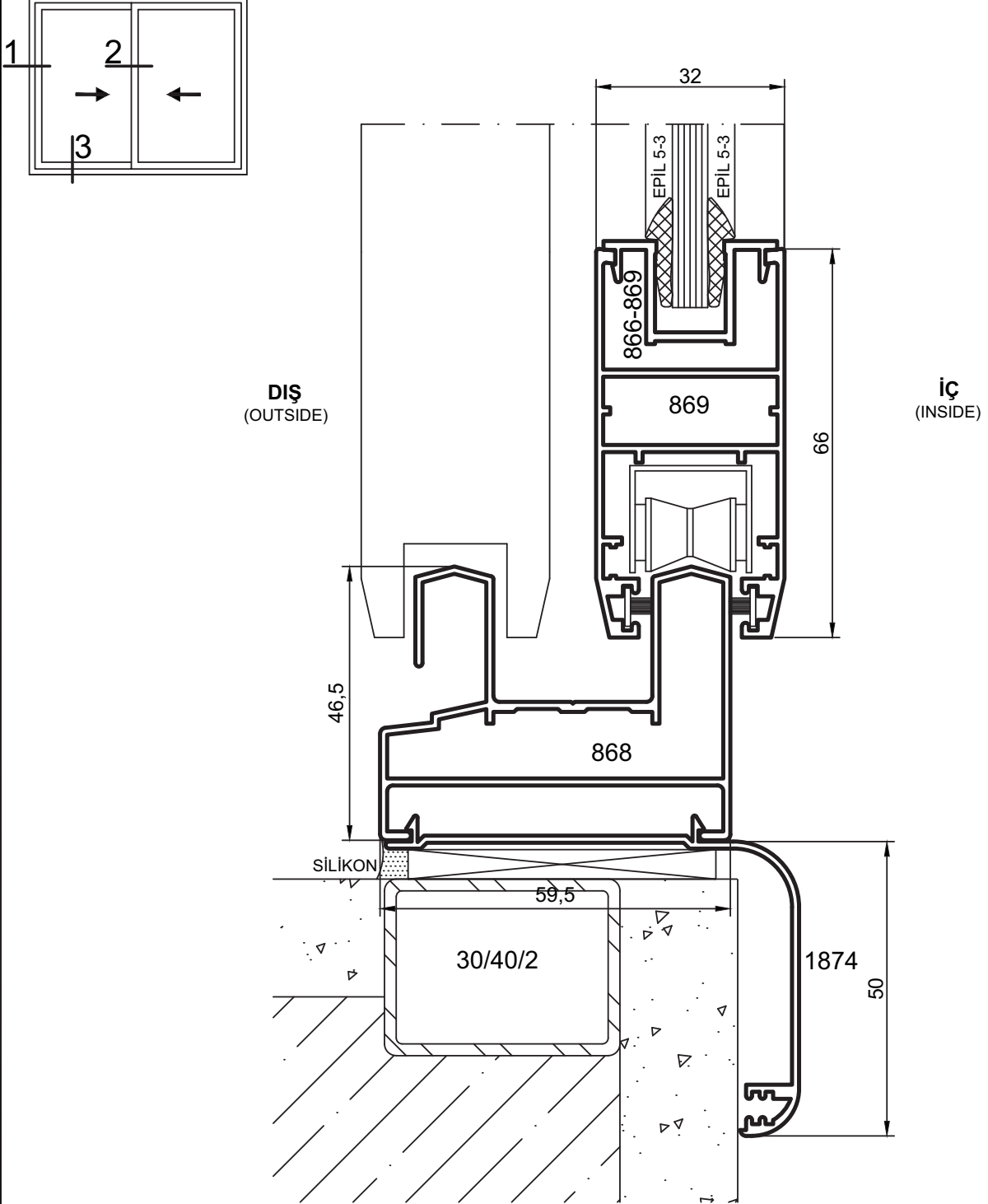

Detay
Detail 3

- Detaylar
- Details

Oval Yalıtımsız Sürme Seri

Sürme 28' lik Seri

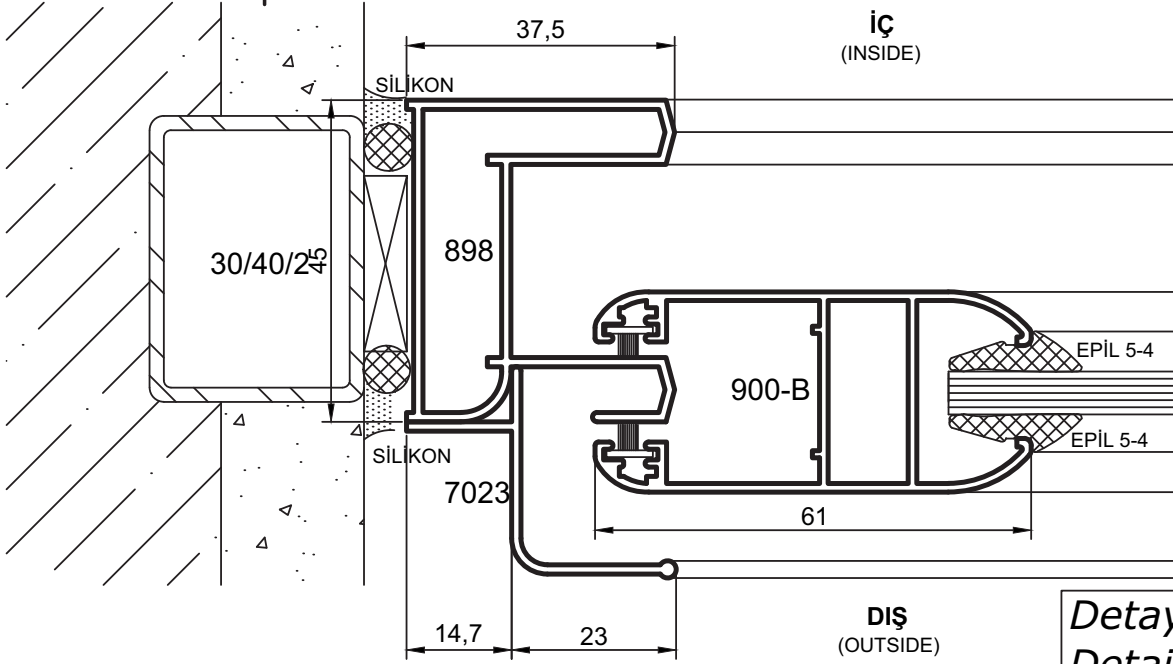
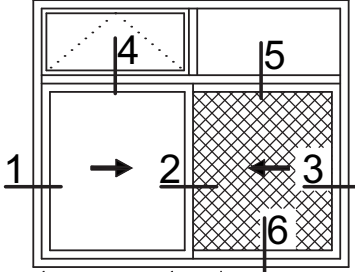

Detay
Detail 1

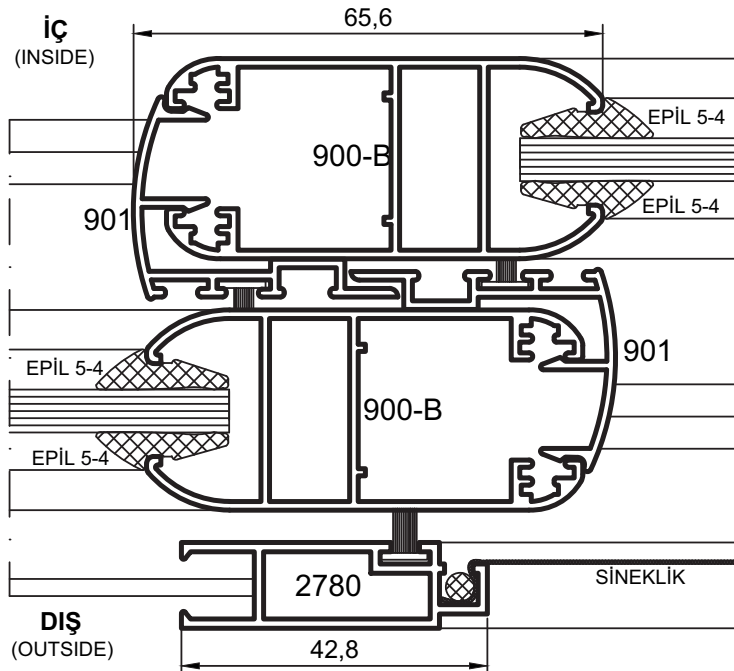

Detay
Detail 2

- Detaylar
- Details

Oval Yalıtımsız Sürme Seri

Sürme 28' lik Seri

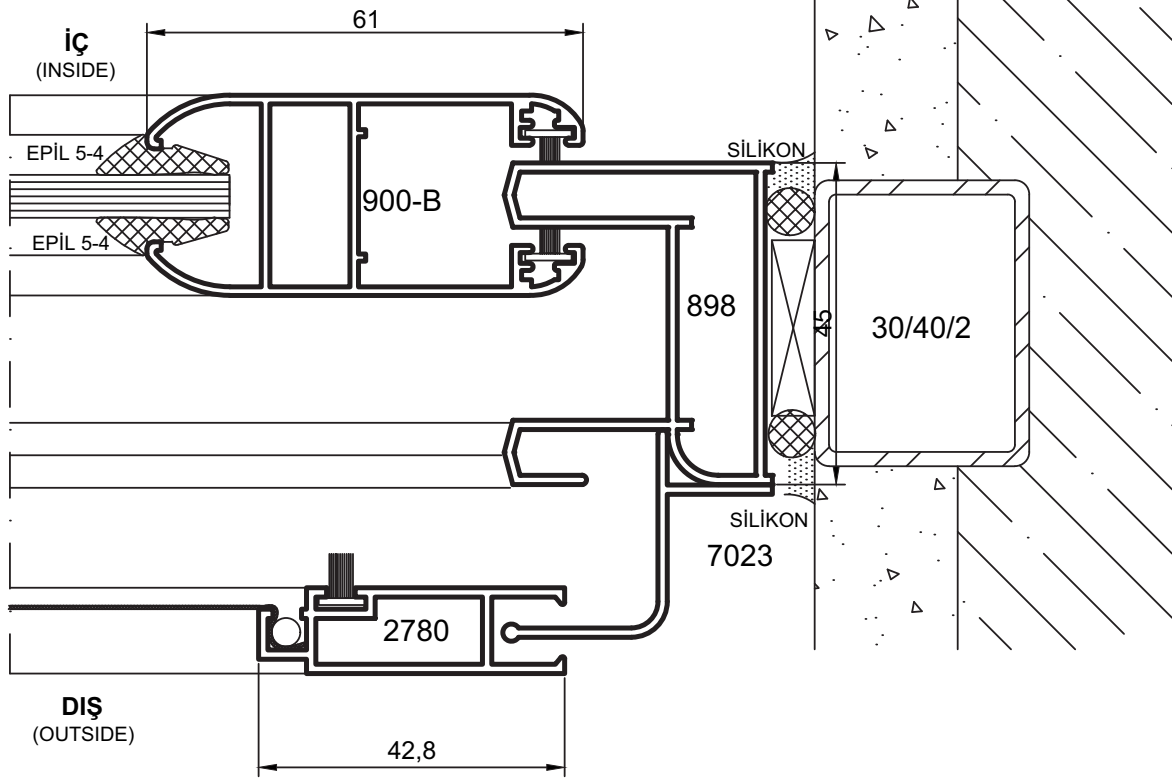
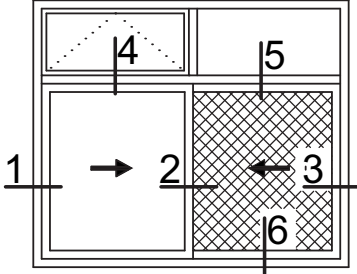

Detay
Detail 3

- Detaylar
- Details

Oval Yalıtımsız Sürme Seri

Sürme 28' lik Seri

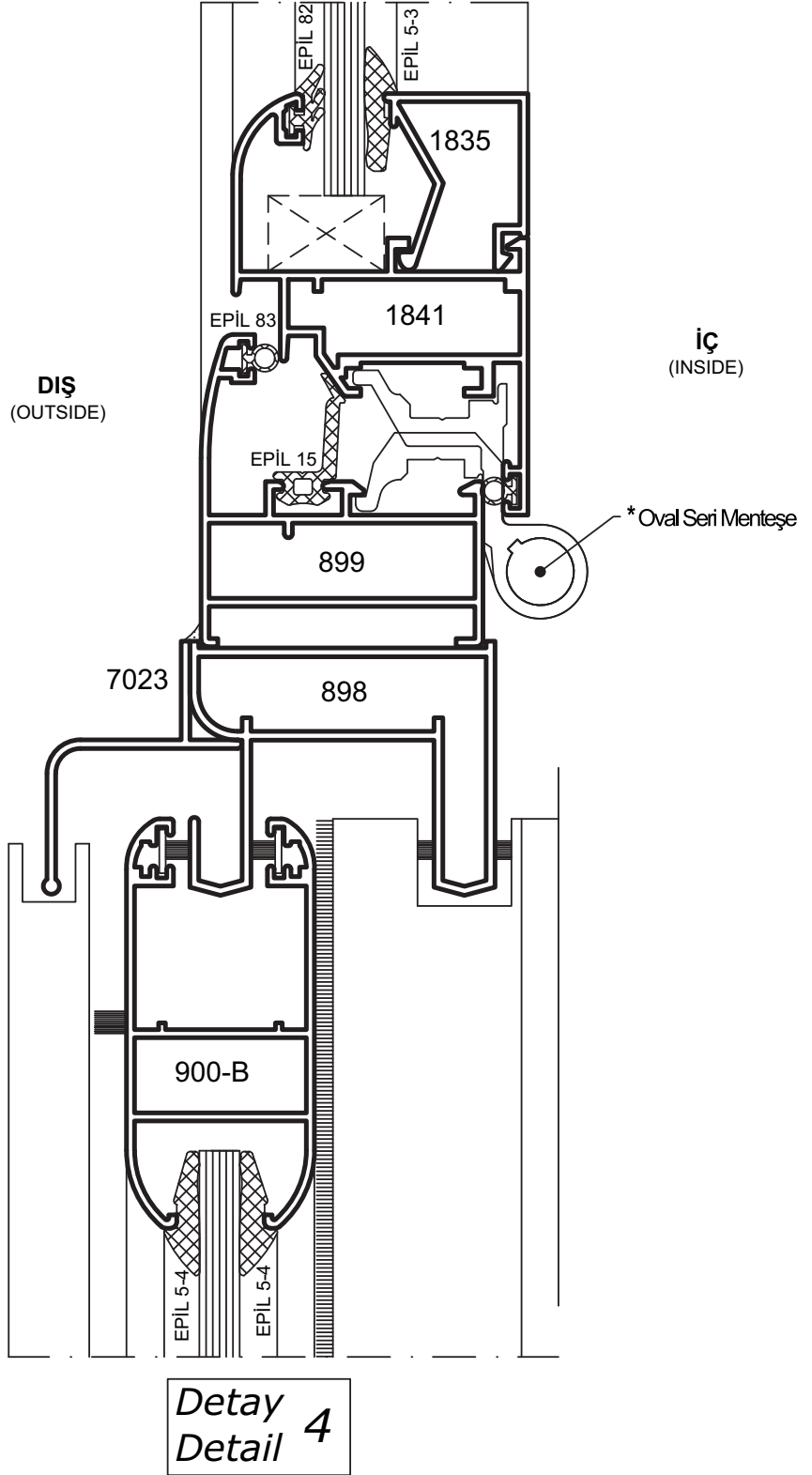
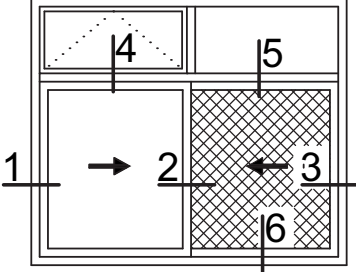

* Aksesuar kodu ile birlikte sipariş veriniz.

- Detaylar
- Details

Oval Yalıtımsız Sürme Seri

Sürme 28' lik Seri

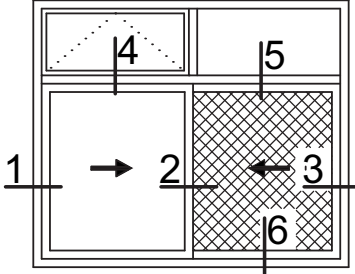

DIŞ
(OUTSIDE)

İÇ
(INSIDE)

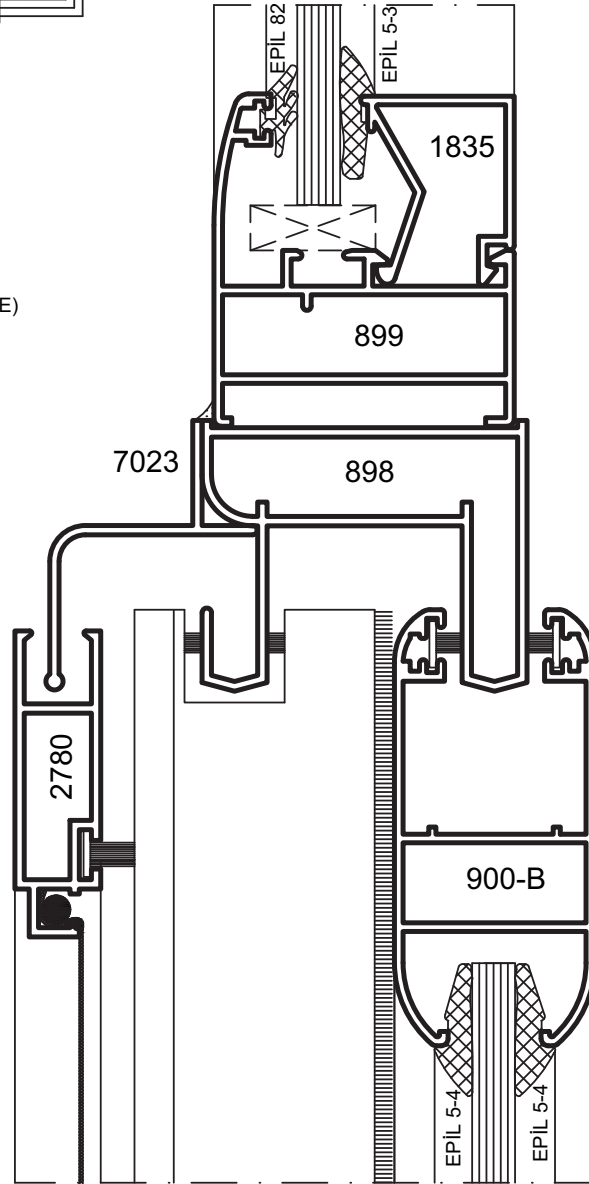

Detay
Detail **5**

- Detaylar
- Details

Oval Yalıtımsız Sürme Seri

Sürme 28' lik Seri

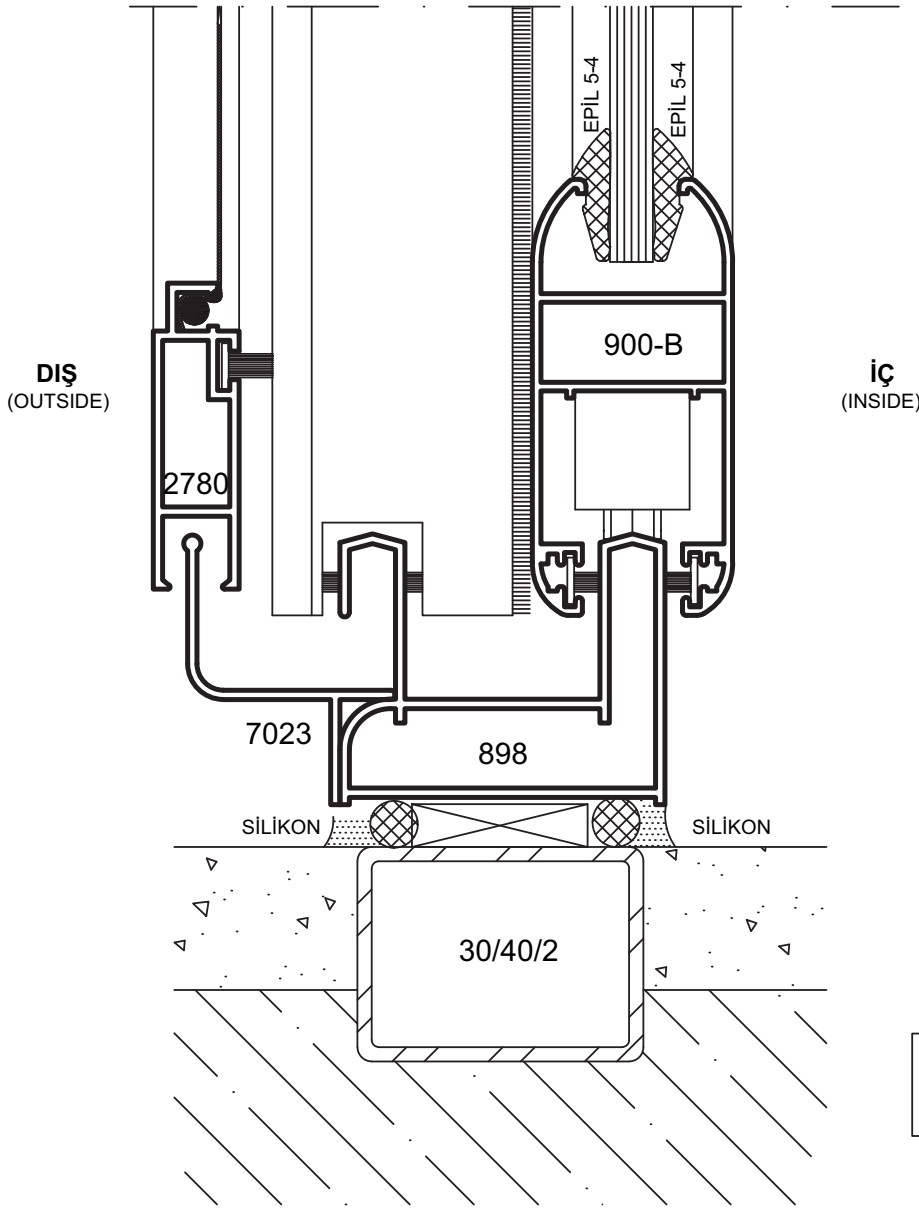
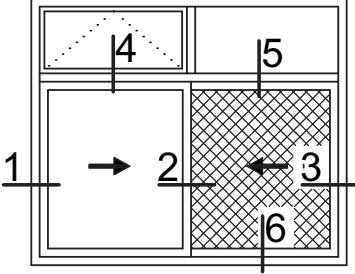

Detay
Detail 6

- Detaylar
- Details

Oval Yalıtımsız Sürme Seri

Sürme 28' lik Seri

